



INTERNATIONAL APPLICATION PUBLISHED UNDER THE PATENT COOPERATION TREATY (PCT)

BEST AVAILABLE COPY

<p>(51) International Patent Classification ⁶ : E05C 9/04</p>	<p>A1</p>	<p>(11) International Publication Number: WO 97/35084 (43) International Publication Date: 25 September 1997 (25.09.97)</p>
<p>(21) International Application Number: PCT/GB97/00687 (22) International Filing Date: 13 March 1997 (13.03.97) (30) Priority Data: 9605462.2 15 March 1996 (15.03.96) GB (71)(72) Applicant and Inventor: MURRAY, Brian [GB/GB]; 14 Bowker Avenue, Haughton Green, Denton, Manchester M34 1GN (GB). (74) Agents: McNEIGHT, David, Leslie et al.; McNeight & Lawrence, Regent House, Heaton Lane, Stockport, Cheshire SK4 1BS (GB).</p>		<p>(81) Designated States: AL, AM, AT, AU, AZ, BA, BB, BG, BR, BY, CA, CH, CN, CU, CZ, DE, DK, EE, ES, FI, GB, GE, GH, HU, IL, IS, JP, KE, KG, KP, KR, KZ, LC, LK, LR, LS, LT, LU, LV, MD, MG, MK, MN, MW, MX, NO, NZ, PL, PT, RO, RU, SD, SE, SG, SI, SK, TJ, TM, TR, TT, UA, UG, US, UZ, VN, YU, ARIPO patent (GH, KE, LS, MW, SD, SZ, UG), Eurasian patent (AM, AZ, BY, KG, KZ, MD, RU, TJ, TM), European patent (AT, BE, CH, DE, DK, ES, FI, FR, GB, GR, IE, IT, LU, MC, NL, PT, SE), OAPI patent (BF, BJ, CF, CG, CI, CM, GA, GN, ML, MR, NE, SN, TD, TG).</p> <p>Published <i>With international search report. Before the expiration of the time limit for amending the claims and to be republished in the event of the receipt of amendments.</i></p>

(54) Title: LOCK

(57) Abstract

There is disclosed an espagnolette type lock comprising: a lateral bolt which is extended laterally from a leaf by key operation; and first and second vertical bolts extending vertically in the leaf and abutting upper and lower faces of said lateral bolt respectively, the second vertical bolt being retained against the lower face of said lateral bolt by resilient means; wherein the lateral bolt comprises upper and lower shaped pieces having inclined leading edges positioned laterally so that lateral extension of the lateral bolt from the leaf drives the first and second vertical bolts into retaining slots positioned in a frame.

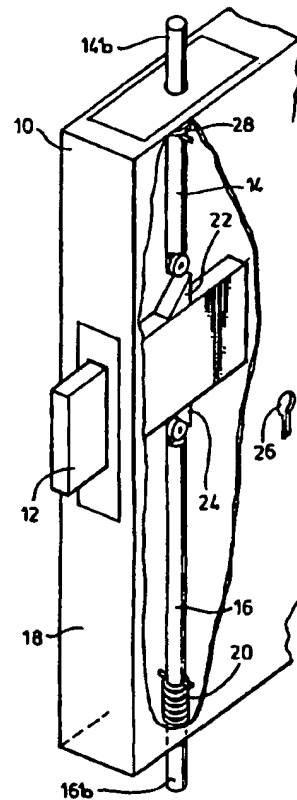

FOR THE PURPOSES OF INFORMATION ONLY

Codes used to identify States party to the PCT on the front pages of pamphlets publishing international applications under the PCT.

AL	Albania	ES	Spain	LS	Lesotho	SI	Slovenia
AM	Armenia	FI	Finland	LT	Lithuania	SK	Slovakia
AT	Austria	FR	France	LU	Luxembourg	SN	Senegal
AU	Australia	GA	Gabon	LV	Latvia	SZ	Swaziland
AZ	Azerbaijan	GB	United Kingdom	MC	Monaco	TD	Chad
BA	Bosnia and Herzegovina	GE	Georgia	MD	Republic of Moldova	TG	Togo
BB	Barbados	GH	Ghana	MG	Madagascar	TJ	Tajikistan
BE	Belgium	GN	Guinea	MK	The former Yugoslav Republic of Macedonia	TM	Turkmenistan
BF	Burkina Faso	GR	Greece			TR	Turkey
BG	Bulgaria	HU	Hungary	ML	Mali	TT	Trinidad and Tobago
BJ	Benin	IE	Ireland	MN	Mongolia	UA	Ukraine
BR	Brazil	IL	Israel	MR	Mauritania	UG	Uganda
BY	Belarus	IS	Iceland	MW	Malawi	US	United States of America
CA	Canada	IT	Italy	MX	Mexico	UZ	Uzbekistan
CF	Central African Republic	JP	Japan	NE	Niger	VN	Viet Nam
CG	Congo	KE	Kenya	NL	Netherlands	YU	Yugoslavia
CH	Switzerland	KG	Kyrgyzstan	NO	Norway	ZW	Zimbabwe
CI	Côte d'Ivoire	KP	Democratic People's Republic of Korea	NZ	New Zealand		
CM	Cameroon			PL	Poland		
CN	China	KR	Republic of Korea	PT	Portugal		
CU	Cuba	KZ	Kazakstan	RO	Romania		
CZ	Czech Republic	LC	Salut Lucia	RU	Russian Federation		
DE	Germany	LI	Liechtenstein	SD	Sudan		
DK	Denmark	LK	Sri Lanka	SE	Sweden		
EE	Estonia	LR	Liberia	SG	Singapore		

LOCK

This invention relates to a locking device, in particular to an espagnolette type device, more particularly still to an espagnolette type device driven by a mortise lock.

It is highly desirable, for security purposes, to provide a plurality of locking bolts for a door, window or the like. One way of achieving this objective is to fit a plurality of locking devices, each requiring a separate key. However, such an arrangement is inconvenient because of the time taken to lock and unlock the individual locking devices.

One solution to this problem is to employ an espagnolette type device wherein the operation of a single component - for example, a handle or a mortise lock - causes bolts to be positioned in securing positions at the top and bottom of the door or window in question. Prior art mechanisms, such as described in, for example, EP 0 509 217 and EP 0 070 576, typically utilise a mechanism for driving the bolts which relies upon fairly complicated internal latch type arrangements.

The present invention provides a simplified espagnolette type arrangement, with particular reference to mortise locks.

According to the invention there is provided an espagnolette type lock comprising :

a lateral bolt which is extended laterally from a leaf by key operation; and

first and second vertical bolts extending vertically in the leaf and abutting upper and lower faces of said lateral bolt respectively, the second vertical bolt being retained against the lower face of said lateral bolt by resilient return means;

wherein the lateral bolt comprises upper and lower shaped pieces having inclined leading edges positioned laterally so that lateral extension of the lateral bolt from the leaf drives the first and second vertical bolts into retaining slots positioned in a frame.

The espagnolette type lock may be used to lock a door, window or a compartment contained within a frame.

The lateral bolt may form part of a mortise lock.

The shaped pieces may be inclined at approximately 45° to the horizontal.

The resilient return means may comprise a spring.

Each vertical bolt may be provided with a wheel, said wheel abutting the lateral bolt.

The vertical bolts may comprise steel, nylon and/or brass rods.

An espagnolette type lock according to the invention will now be described with reference to the accompanying drawings, in which:-

Figure 1 is a cross sectional side view of a lock of a first embodiment in a locked position;

Figure 2 is a cross sectional side view of a lock of the first embodiment in an unlocked position;

Figure 3 is a partially cut away elevation of a lock of the first embodiment in a locked position;

Figure 4 is a cross sectional side view of a lock of a second embodiment;

Figure 5 is an elevation of a lock of the second embodiment; and

Figure 6 is a view of the top portion of a lock of the second embodiment.

Figures 1 to 3 show an espagnolette type lock comprising:

a lateral bolt 12 which is extended laterally from the leaf 18 by key operation; and

- 4 -

first and second vertical bolts 14, 16 extending vertically in the leaf 18 and abutting upper 12a and lower 12b faces of said lateral bolt 12 respectively, the second vertical bolt 16 being retained against the lower face 12b of said lateral bolt 12 by resilient return means 20;

wherein the lateral bolt 12 comprises upper and lower shaped pieces 22, 24 having inclined leading edges 22a, 24a positioned laterally so that the lateral extension of the lateral bolt 12 from the leaf 18 drives the first and second vertical bolts 14, 16 into retaining slots (not shown) positioned in the frame.

The espagnolette type lock of Figures 1 to 3 is used to lock a door 10. However, locks of the present type can be used also to lock windows or, indeed any type of compartment contained within a frame. An example of such a compartment is a cash box disposed within a structure such as a fruit machine, arcade video game or a pool table.

Advantageously, the lateral bolt 12 forms part of a mortise lock having a key hole 26. For simplicity of presentation the internal mechanism of the mortise lock is not shown in Figures 1 to 3.

The shaped pieces 22, 24 are inclined at approximately 45° to the horizontal, although it is understood that the invention is not limited to such angle of inclination. Indeed, in general, the shallower the angle of inclination the more reliably and smoothly the vertical bolts 14, 16 are driven. However, this is offset by the fact that, for a given lateral length of travel, shallower angles of inclination result in smaller

vertical travel for the vertical bolts 14, 16. An angle of inclination of around 45° from the horizontal appears to represent an acceptable compromise.

The resilient return means 20 is a spring, positioned towards the lower edge of the leaf. The spring ensures that the second vertical bolt 16 abuts the lateral bolt 12 at all times. The first vertical bolt 14 may also be provided with a spring 28, positioned towards the upper edge of the leaf.

The vertical bolts 14, 16 are provided with wheels 14a, 16a, said wheels 14a, 16a abutting the lateral bolt 12. The purpose of the wheels is to produce a smooth and free vertical bolt driving action. Excessive horizontal motion of the vertical bolts 14, 16 may result in jamming of the device.

The vertical bolts 14, 16 are stainless steel rods. The shaped pieces 22, 24 may be integral with the rectangular 'slab' portion of the lateral bolt 12. Alternatively, it is possible to adapt a conventional mortise lock to produce a lock of the present invention by fitting shaped pieces to the mortise bolt and installing vertical bolts into the door leaf.

Figure 2 is a cross sectional view of the lock arrangement in an unlocked state. To lock the arrangement the key is positioned in the keyhole 26 and turned, causing the lateral bolt 12 to locate in the frame in the usual manner. The accompanying lateral translational of the shaping pieces 22, 24 drives the first and second vertical bolts 14, 16 upwards and downwards, respectively, forcing the ends 14b, 16b thereof out of the leaf 18. The extent of this upward and downward motion is sufficient to securely

position the ends 14b, 16b of vertical bolts 14, 16 in retaining slots (not shown) positioned in the frame. Typically, the lateral translation of the lateral bolt 12 upon locking is ca. 15mm which, with shaping pieces 22, 24 inclined at 45° to the horizontal, produces up to 15mm vertical translation of the vertical bolts 14, 16. Figures 1 and 3 show the lock arrangement in a locked state.

Figures 4 to 6 show another embodiment of an espagnolette type lock which, due to its physical dimensions, is suitable for use as a sash window lock. However, it is understood that use in the other applications described above, i.e. in doors and compartments, and also in casement windows, is also within the scope of the invention.

The espagnolette type lock comprises a brass lateral bolt 40 having upper and lower shaped pieces 42, 44 integral therewith. The lateral bolt 40 is driven by a three lever lock system 46 (shown - semi schematically - in Figure 4 only) which produces a lateral translation of the lateral bolt 40 upon locking of 12 mm. The three lever lock 46 and lateral bolt 40 are contained within a stainless steel casing 48 having nylon bushes 50, 52 through which the vertical bolts 54, 56 are driven. The vertical bolts 54, 56 are (in vicinity of the bushes 50, 52) fabricated in nylon, and have an outer diameter of 6 mm. The width W and height H of the casing 48 are 34 mm and 72 mm, respectively. The physical dimensions of the espagnolette type lock render it suitable for use with sash windows. The use of nylon bushes 50, 52 and nylon vertical bolts 54, 56 permits smooth translation of said bolts 54, 56. It is also possible to provide impacting components such as the shaped pieces and the vertical bolts with a polymeric coating in order to reduce abrasion.

Figures 5 and 6 depict the mechanism by which the vertical bolts 54, 56 are retained in the frame (not shown). In addition to the 6 mm OD nylon rods, the vertical bolts 54, 56 further comprise brass rods 58, 60. The brass rods comprise locating portions 58a, 60a, having an inner bore into which the respective nylon rods locate. Advantageously, the diameter of the inner bore is slightly larger than the OD of the nylon rod, i.e. the inner bore diameter can be 7 mm when the OD of the nylon rod is 6 mm. In this manner, an attempt by a thief to use a blade, such as a hacksaw, to cut through the brass rods 58, 60 will be thwarted because of the free rotation of the brass rods 58, 60 about the nylon rods. The brass rods 58, 60 further comprise elongate portions 58b, 60b, of smaller OD than the locating portions 58a, 60a, thereby conveniently housing springs 62, 64. The brass rods 58, 60 reciprocate through self-tapping brass bushes 66, 68 which are conveniently located in the sash. When the sash is locked, the brass rods 58, 60 are driven by the action of the shaped pieces 42, 44, via the movement of the nylon rods, into self-tapping brass bushes 70, 72 which are conveniently located in a frame. Advantageously, the ID of the bushes 70, 72 is somewhat larger than the OD of the brass rods 58, 60 - for example, 15 mm vs 10 mm. In this way, any moderate misalignment of sash and frame occurring over time is corrected for.

It will be apparent from the foregoing that numerous materials and configurations are suitable for the purpose of reducing the invention to practice.

An advantage of locks of the present invention is that a single key turning operation results in locking at three, well separated locations. A further advantage is that the driving mechanism is very simple and inexpensive, in contrast to prior art mechanisms which rely on rather complicated latch type arrangements. A further

advantage still is that conventional mortise locks may be readily adapted to produce a lock of the present invention.

CLAIMS

1. An espagnolette type lock comprising :

a lateral bolt which is extended laterally from a leaf by key operation; and

first and second vertical bolts extending vertically in the leaf and abutting upper and lower faces of said lateral bolt respectively, the second vertical bolt being retained against the lower face of said lateral bolt by resilient means;

wherein the lateral bolt comprises upper and lower shaped pieces having inclined leading edges positioned laterally so that lateral extension of the lateral bolt from the leaf drives the first and second vertical bolts into retaining slots positioned in a frame.
2. A lock according to claim 1 used to lock a door.
3. A lock according to claim 1 used to lock a window.
4. A lock according to claim 1 used to lock a compartment contained within a frame.
5. A lock according to any of the previous claims in which the lateral bolt forms part of a mortise lock.

6. A lock according to any of the previous claims in which the shaped pieces are inclined at approximately 45° to the horizontal.
7. A lock according to any of the previous claims in which the resilient return means comprises a spring.
8. A lock according to any of the previous claims in which each vertical bolt is provided with a wheel, the wheel abutting the lateral bolt.
9. A lock according to any of the previous claims in which the vertical bolts comprise steel, nylon and/or brass rods.

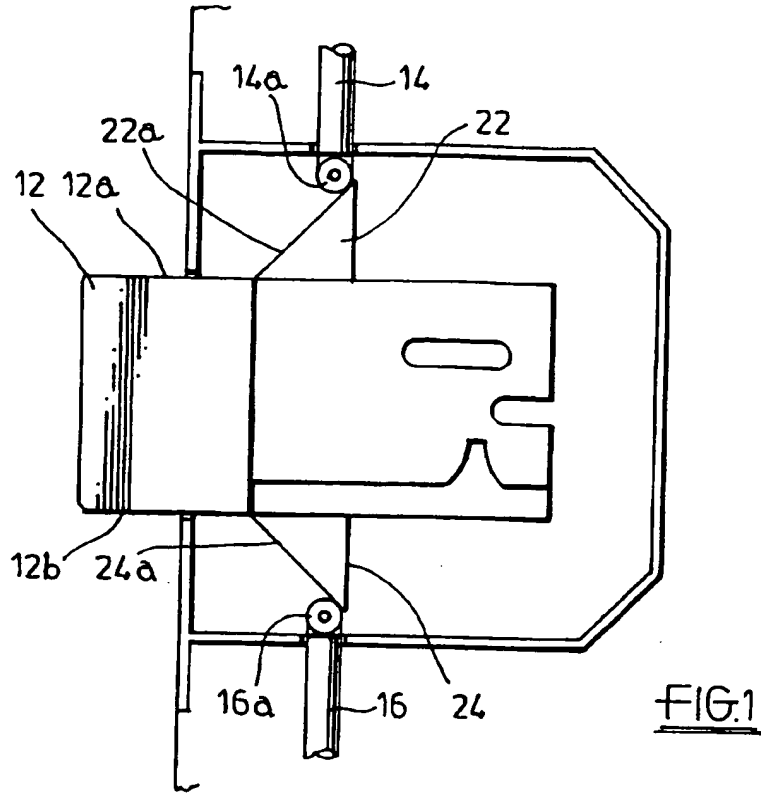

FIG.1

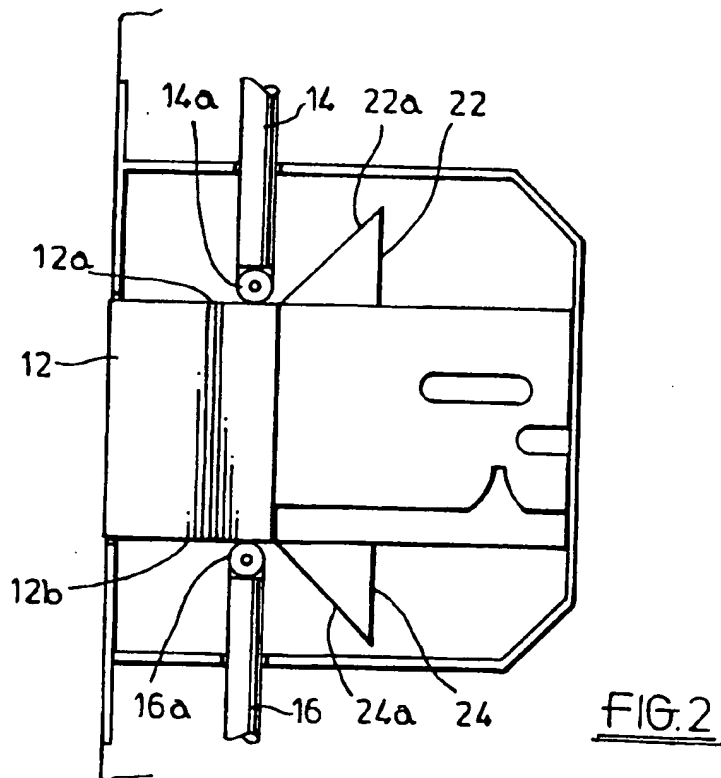

FIG.2

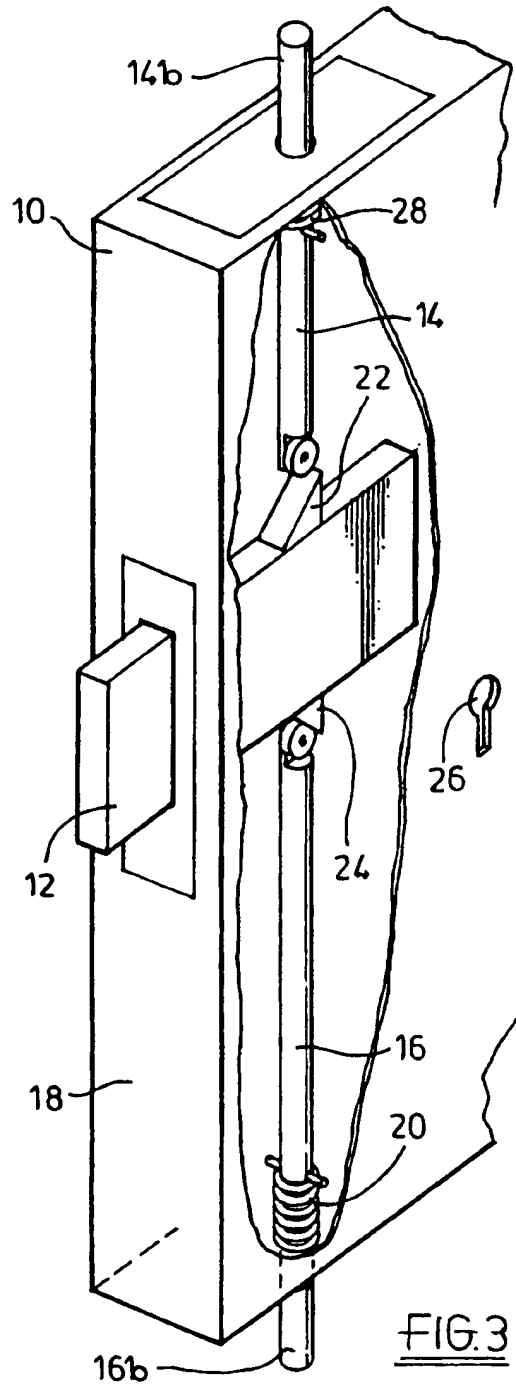
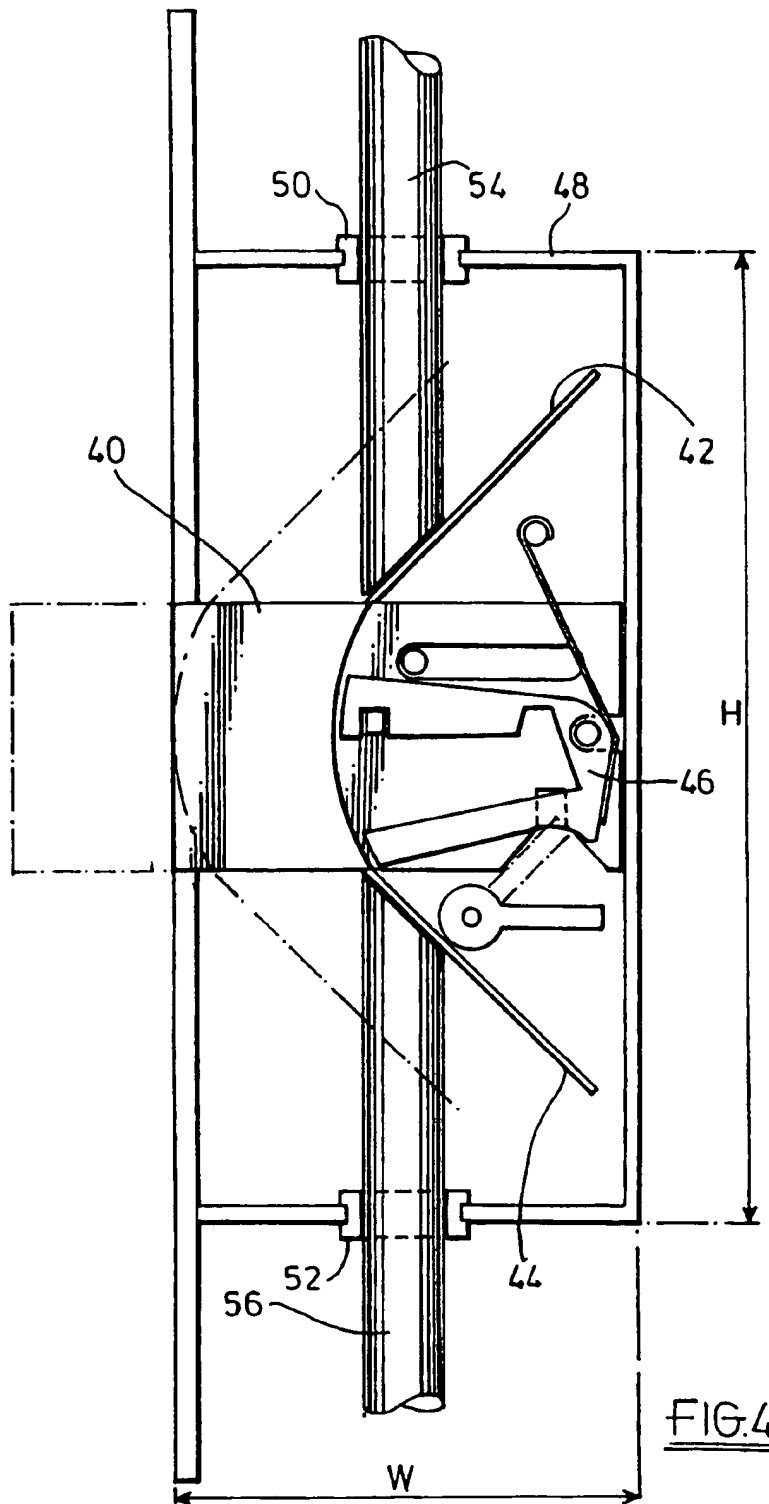
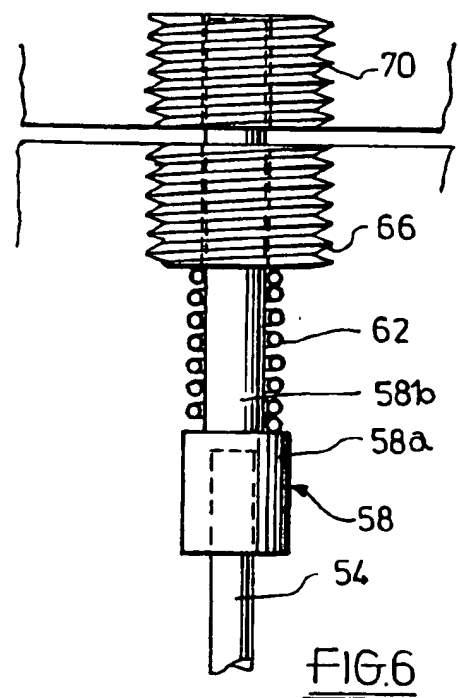
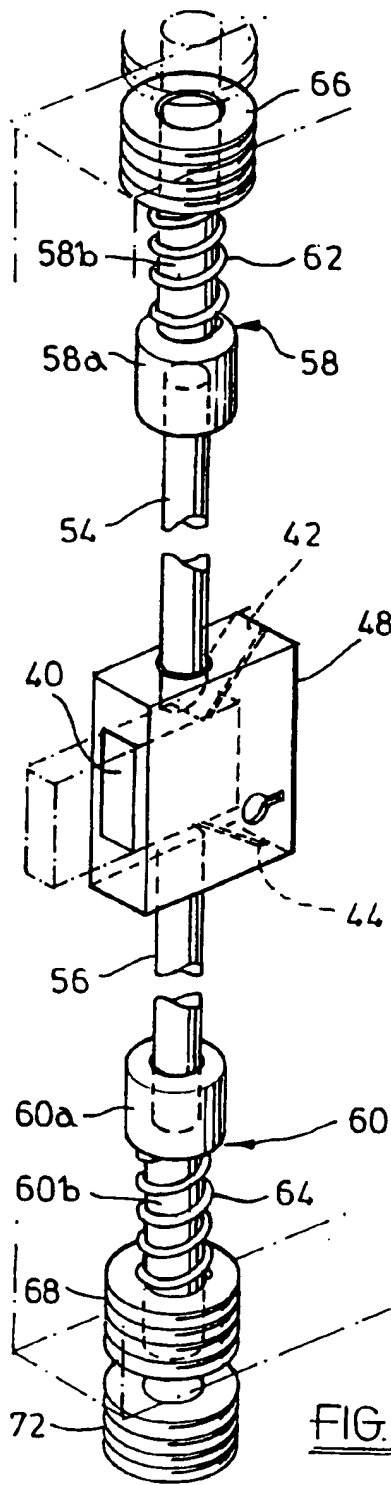

FIG. 3

3/4





INTERNATIONAL SEARCH REPORT

In tional Application No
PCT/GB 97/00687

A. CLASSIFICATION OF SUBJECT MATTER IPC 6 E05C9/04		
According to International Patent Classification (IPC) or to both national classification and IPC		
B. FIELDS SEARCHED		
Minimum documentation searched (classification system followed by classification symbols) IPC 6 E05C		
Documentation searched other than minimum documentation to the extent that such documents are included in the fields searched		
Electronic data base consulted during the international search (name of data base and, where practical, search terms used)		
C. DOCUMENTS CONSIDERED TO BE RELEVANT		
Category *	Citation of document, with indication, where appropriate, of the relevant passages	Relevant to claim No.
X	FR 2 629 508 A (HERVOUET GASTON ;HERVOUET JACQUELINE (FR)) 6 October 1989 see page 2, line 30 - page 5, line 31; figures	1-9
X	--- DE 33 27 211 C (SÄLZER) 14 February 1985 see column 2, line 67 - column 3, line 37; figures	1-7
X	--- DE 21 40 554 A (TUTIKAWA ZENJI) 22 February 1973	1-7
A	see page 3, line 20 - page 7, line 5; figures	9
X	--- US 1 633 508 A (BARON, ET.AL.) 21 June 1927 see page 2, line 4 - page 3, line 108; figures	1-3,5-8
--- -/--		
<input checked="" type="checkbox"/> Further documents are listed in the continuation of box C.		
<input checked="" type="checkbox"/> Patent family members are listed in annex.		
* Special categories of cited documents :		
'A' document defining the general state of the art which is not considered to be of particular relevance	'T' later document published after the international filing date or priority date and not in conflict with the application but cited to understand the principle or theory underlying the invention	
'E' earlier document but published on or after the international filing date	'X' document of particular relevance; the claimed invention cannot be considered novel or cannot be considered to involve an inventive step when the document is taken alone	
'L' document which may throw doubts on priority claim(s) or which is cited to establish the publication date of another citation or other special reason (as specified)	'Y' document of particular relevance; the claimed invention cannot be considered to involve an inventive step when the document is combined with one or more other such documents, such combination being obvious to a person skilled in the art.	
'O' document referring to an oral disclosure, use, exhibition or other means	'B' document member of the same patent family	
'P' document published prior to the international filing date but later than the priority date claimed		
Date of the actual completion of the international search <p style="text-align: center;">10 July 1997</p>	Date of mailing of the international search report <p style="text-align: center;">18.07.97</p>	
Name and mailing address of the ISA European Patent Office, P.B. 5818 Patentlaan 2 NL - 2280 HV Rijswijk Tel. (+ 31-70) 340-2040, Tx. 31 651 epo nl, Fax: (- 31-70) 340-3016	Authorized officer <p style="text-align: center;">Henkes, R</p>	

INTERNATIONAL SEARCH REPORT

International Application No
PCT/GB 97/00687

C.(Continuation) DOCUMENTS CONSIDERED TO BE RELEVANT		
Category *	Citation of document, with indication, where appropriate, of the relevant passages	Relevant to claim No.
A	FR 2 681 369 A (AIMO MICHEL) 19 March 1993 see the whole document ---	1-3,5-7
A	EP 0 400 534 A (OTLAV SPA) 5 December 1990 see column 13, line 9 - line 16 -----	9

INTERNATIONAL SEARCH REPORT

Information on patent family members

International Application No
PCT/GB 97/00687

Patent document cited in search report	Publication date	Patent family member(s)	Publication date
FR 2629508 A	06-10-89	NONE	
DE 3327211 C	14-02-85	NONE	
DE 2140554 A	22-02-73	NONE	
US 1633508 A	21-06-27	NONE	
FR 2681369 A	19-03-93	NONE	
EP 0400534 A	05-12-90	AT 140757 T	15-08-96
		DE 69027893 D	29-08-96
		DE 69027893 T	12-12-96
		ES 2091210 T	01-11-96
		SU 1822457 A	15-06-93
		US 5076015 A	31-12-91